

ΧΥΤΟΣΙΔΗΡΟΣ ΣΩΛΗΝΑΣ



Κωδικός	DN	OD max (mm)	+ (mm)	- (mm)	L (mm)	Kg / Τεμ.	€ / Μέτρο
156342	40	48	2	1	3000	8,90	
156360	50	58	2	1	3000	12,50	
156454	70	78	2	1	3000	17,70	
156560	100	110	2	1	3000	24,30	
156733	125	135	2	2	3000	34,30	
156824	150	160	2	2	3000	40,90	
156948	200	210	2,5	2,5	3000	67,40	
157047	250	274	2,5	2,5	3000	97,30	
157112	300	326	2,5	2,5	3000	126,80	

ΧΥΤΟΣΙΔΗΡΗ ΓΩΝΙΑ 15°



Κωδικός	DN	b (mm)	H (mm)	h (mm)	Kg / Τεμ.	€ / Τεμ.
155752	50	66	80	66	0,40	
155781	70	88	98	78	0,60	
155816	100	121	112	83	1,00	
155870	125	148	134	99	1,70	
155903	150	173	148	108	2,50	
155932	200	227	184	129	4,60	

ΧΥΤΟΣΙΔΗΡΗ ΓΩΝΙΑ 22°



Κωδικός	DN	b (mm)	H (mm)	h (mm)	Kg / Τεμ.	€ / Τεμ.
156388	50	70	88	66	0,45	
156598	100	126	125	84	1,30	
156761	125	152	143	92	1,85	
156855	150	179	162	102	2,60	
156974	200	233	200	122	4,40	

ΧΥΤΟΣΙΔΗΡΗ ΓΩΝΙΑ 30°



Κωδικός	DN	b (mm)	H (mm)	h (mm)	Kg / Τεμ.	€ / Τεμ.
155753	50	76	97	69	0,50	
155782	70	97	112	73	0,70	
155817	100	132	136	81	1,30	
155871	125	160	164	96	2,00	
155904	150	189	188	108	3,00	
155933	200	243	229	124	5,40	

ΧΥΤΟΣΙΔΗΡΗ ΓΩΝΙΑ 45°

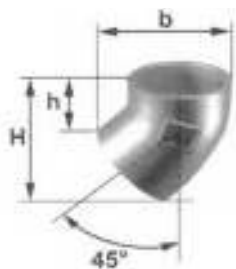

Κωδικός	DN	b (mm)	H (mm)	h (mm)	Kg / Τεμ.	€ / Τεμ.
156384	50	84	106	65	0,55	
155780	70	108	129	74	0,90	
156593	100	142	158	80	1,57	
156756	125	171	184	89	2,12	
156850	150	199	210	97	3,19	
156970	200	256	262	113	5,25	

ΧΥΤΟΣΙΔΗΡΗ ΓΩΝΙΑ 68°

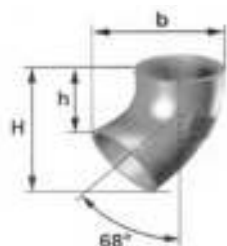

Κωδικός	DN	b (mm)	H (mm)	h (mm)	Kg / Τεμ.	€ / Τεμ.
156382	50	104	123	70	0,75	
155779	70	123	139	67	1,10	
156591	100	159	176	84	1,80	
156754	125	188	205	80	3,00	
156847	150	219	237	89	4,10	
156968	200	277	295	99	7,78	

ΧΥΤΟΣΙΔΗΡΗ ΓΩΝΙΑ 88°

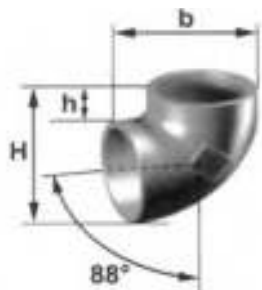

Κωδικός	DN	b (mm)	H (mm)	h (mm)	Kg / Τεμ.	€ / Τεμ.
156379	50	104	107	49	0,80	
155778	70	130	132	54	1,40	
156588	100	166	169	59	2,22	
156752	125	194	197	62	2,85	
156844	150	227	130	70	4,34	
156966	200	267	191	81	8,10	

ΧΥΤΟΣΙΔΗΡΗ ΓΩΝΙΑ 88° ΜΕ ΠΩΜΑ ΚΑΘΑΡΙΣΜΟΥ

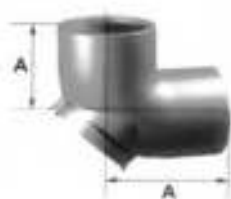

Κωδικός	DN	Kg / Τεμ.	€ / Τεμ.
156589	100	3,30	

ΧΥΤΟΣΙΔΗΡΟ ΤΑΦ 88° ΜΕ ΠΩΜΑ ΚΑΘΑΡΙΣΜΟΥ

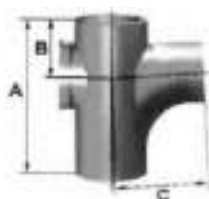

Κωδικός	DN	dn	B (mm)	C (mm)	Kg / Τεμ.	€ / Τεμ.
156697	100	100	102	150	4,30	

ΧΥΤΟΣΙΔΗΡΟ ΤΑΦ 45°

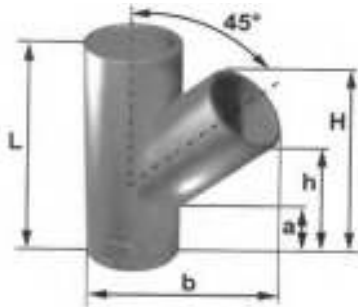

Κωδικός	DN	dn	L (mm)	b (mm)	H (mm)	h (mm)	a (mm)	Kg / Τεμ.	€ / Τεμ.
156435	50	50	185	144	165	124	36	1,15	
155789	70	50	190	124	166	125	35	1,60	
155806	70	70	215	179	195	140	35	2,30	
156618	100	50	200	191	172	131	47	2,45	
155831	100	70	235	213	208	153	48	3,50	
156701	100	100	275	238	253	175	45	3,95	
156775	125	100	280	261	254	177	47	5,15	
156813	125	125	320	284	296	201	49	5,80	
156879	150	100	295	287	262	185	54	6,10	
156883	150	125	325	307	298	202	52	7,30	
156931	150	150	355	323	333	219	53	8,70	
156982	200	100	305	330	266	188	63	8,80	
156984	200	125	335	350	300	204	62	10,00	
156989	200	150	375	373	343	230	63	11,10	
157030	200	200	455	418	428	280	68	15,80	

ΧΥΤΟΣΙΔΗΡΟ ΤΑΦ 68°

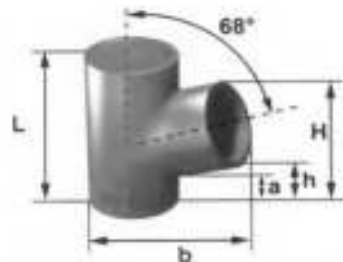

Κωδικός	DN	dn	L (mm)	b (mm)	H (mm)	h (mm)	a (mm)	Kg / Τεμ.	€ / Τεμ.
156433	50	50	145	118	117	65	37	1,10	
155805	70	70	170	146	143	71	40	1,70	
156616	100	50	155	168	123	69	43	1,80	
155830	100	70	180	180	150	79	43	2,40	
156699	100	100	220	195	189	87	50	2,95	
156773	125	100	225	222	190	88	50	3,80	
156811	125	125	225	235	220	95	50	4,45	

ΧΥΤΟΣΙΔΗΡΟ ΤΑΦ 88°

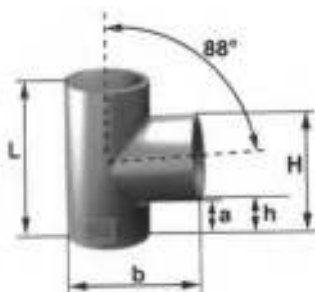

Κωδικός	DN	dn	L (mm)	b (mm)	H (mm)	h (mm)	a (mm)	Kg / Τεμ.	€ / Τεμ.
156431	50	50	145	110	111	53	31	1,10	
155787	70	50	160	132	117	59	43	1,40	
155804	70	70	180	135	139	61	38	1,70	
156613	100	50	170	161	127	69	45	2,25	
155829	100	70	199	166	145	67	45	2,40	
156695	100	100	220	172	174	64	41	2,90	
156768	125	50	180	188	131	73	51	2,80	
155878	125	70	200	194	150	72	48	3,40	
155880	125	100	235	199	184	74	48	4,00	
156809	125	125	260	205	209	74	48	4,50	
156874	150	100	245	237	190	80	52	4,90	
155913	150	125	275	232	220	85	56	5,70	
156925	150	150	300	237	243	83	55	6,50	
157024	200	200	365	388	296	86	10,8	11,10	

ΧΥΤΟΣΙΔΗΡΟΣ ΣΤΑΥΡΟΣ 45°



Κωδικός	DN	dn	L (mm)	b (mm)	H (mm)	h (mm)	a (mm)	Kg / Τεμ.	€ / Τεμ.
156709	100	100	260	346	243	165	46	4,50	
156817	125	125	305	421	285	190	45	7,30	
156936	150	150	355	488	334	277	55	11,70	

ΧΥΤΟΣΙΔΗΡΟΣ ΣΤΑΥΡΟΣ 68°

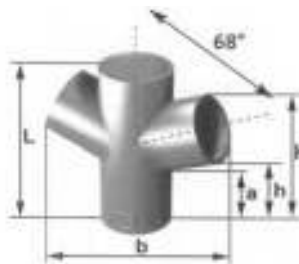

Κωδικός	DN	dn	L (mm)	b (mm)	H (mm)	h (mm)	a (mm)	Kg / Τεμ.	€ / Τεμ.
156707	100	100	220	195	189	87	50	3,90	
156766	125	100	225	222	190	88	50	4,40	
156934	150	150	295	276	256	108	57	8,10	

ΧΥΤΟΣΙΔΗΡΟΣ ΣΤΑΥΡΟΣ 88°

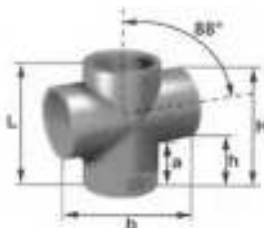

Κωδικός	DN	dn	L (mm)	b (mm)	H (mm)	h (mm)	a (mm)	Kg / Τεμ.	€ / Τεμ.
156704	100	100	230	243	179	69	49	3,20	
155907	150	100	245	294	190	80	52	7,10	

ΧΥΤΟΣΙΔΗΡΕΣ ΣΥΣΤΟΛΕΣ



Κωδικός	DN	dn	L (mm)	h (mm)	Kg / Τεμ.	€ / Τεμ.
155763	70	50	75	42	0,50	
156426	100	50	80	45	1,00	
155801	100	70	85	45	0,90	
155802	125	70	90	50	1,50	
156684	125	100	95	50	1,60	
156686	150	100	105	60	2,30	
156805	150	125	110	60	1,95	
156688	200	100	115	70	3,65	
156807	200	125	120	70	3,45	
156919	200	150	125	65	3,85	

ΧΥΤΟΣΙΔΗΡΑ ΤΕΡΜΑΤΙΚΑ



Κωδικός	DN	L (mm)	Kg / Τεμ.	€ / Τεμ.
156376	50	30	0,25	
155776	70	35	0,40	
156581	100	40	0,80	
156749	125	45	1,20	
156841	150	50	1,70	
156963	200	60	3,20	

ΧΥΤΟΣΙΔΗΡΑ ΤΕΡΜΑΤΙΚΑ ΑΣΦΑΛΕΙΑΣ

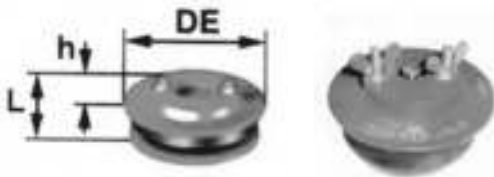

Κωδικός	DN	L (mm)	h (mm)		Kg / Τεμ.	€ / Τεμ.
156374	50	48	15		0,25	
156468	70	63	11		0,50	
156579	100	81	26		1,00	
156747	125	82	29		1,50	
156839	150	88	35		2,25	
156961	200	100	37		4,20	

ΧΥΤΟΣΙΔΗΡΟ ΕΞΑΡΤΗΜΑ ΓΙΑ ΚΑΤΑΚΟΡΥΦΗ ΣΤΗΛΗ ΜΕ ΧΥΤΟΣΙΔΗΡΗ ΦΛΑΝΤΖΑ ΣΤΗΡΙΞΗΣ

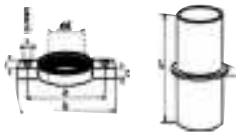

Κωδικός	DN	L (mm)	a (mm)	B (mm)	c (mm)	d (mm)	e (mm)	Kg / Τεμ.	€ / Τεμ.
177742	70	200	170	215	30	19	8	2,80	
156657	100	220	214	259	32	205	8	4,50	
156793	125	220	228	275	32	20	8	5,50	
156904	150	220	255	300	32	22	8	7,20	
157014	200	220	310	362	36	22	8	10,00	

ΧΥΤΟΣΙΔΗΡΟ ΠΩΜΑ ΚΑΘΑΡΙΣΜΟΥ

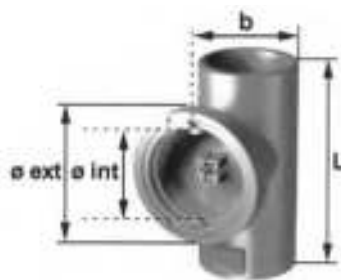

Κωδικός	DN	L (mm)	B (mm)	Φ int (mm)	Φ ext (mm)	Kg / Τεμ.	€ / Τεμ.
156414	50	160	102	75	108	1,9	
155799	70	205	132	101	134	3,0	
156659	100	250	157	128	160	4,5	
156794	125	280	192	154	189	6,5	
156905	150	320	222	181	224	10,4	
157015	200	360	270	181	224	12,75	

ΧΥΤΟΣΙΔΗΡΑ ΣΙΦΩΝΙΑ ΓΙΑ ΟΜΒΡΙΑ



Κωδικός	DN	L (mm)	b (mm)	h1 (mm)	a (mm)	c (mm)	H (mm)	Kg / Τεμ.	€ / Τεμ.
156420	50	240	190	143	33	112	201	2,90	
156521	70	280	264	150	43	162	230	5,48	
156668	100	381	325	216	15	216	326	9,50	
156801	125	435	390	238	12	266	372	13,10	
156912	150	482	470	257	8	340	417	21,80	

• Τα βέλη πάνω σε αυτό δείχνουν τη φορά τοποθέτησης

ΧΥΤΟΣΙΔΗΡΟ ΣΙΦΩΝΙ ΜΕ ΤΑΠΑ ΚΑΘΑΡΙΣΜΟΥ



Κωδικός	DN	B (mm)		Kg / Τεμ.	€ / Τεμ.
156518	70	138		2,70	
156667	100	175		5,20	
156911	150	240		12,10	

ΧΥΤΟΣΙΔΗΡΗ ΓΩΝΙΑ ΓΙΑ WC

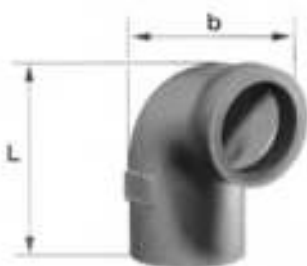

Κωδικός	DN	b (mm)	L (mm)	Kg / Τεμ.	€ / Τεμ.
155852	100	139	217	2,85	

ΑΝΟΞΕΙΔΩΤΟΙ ΣΥΝΔΕΣΜΟΙ CV NG

NEO!

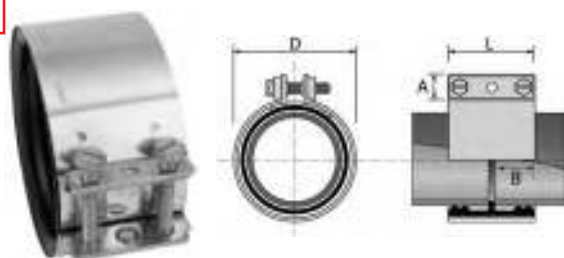

Κωδικός	DN	B (mm)	D (mm)	H (mm)	L (mm)	€ / Τεμ.
210398	50	22,5	70	85	45	
210400	70	22,5	90	105	48	
210416	100	25,5	122	140	54	
210417	125	25,5	147	165	54	
210418	150	25,5	172	190	54	
210420	200	38	222	240	78	

Δοκιμή σε υδροστατική πίεση:

- DN 50 έως DN 100: 10 bars
- DN 150 έως DN 100: 5 bars

ΣΥΝΔΕΣΜΟΙ ΑΣΦΑΛΕΙΑΣ (GRIP COLLARS) ΓΙΑ CV

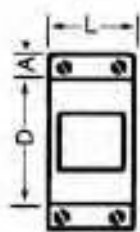

Κωδικός	DN	A (mm)	D (mm)	L (mm)	Md [Nm]	€ / Τεμ.
155760	50	23	74	71	10-12	
155792	70	23	94	71	10-12	
155834	100	23	124	87	18-20	
155884	125	23	149	98	18-20	
155915	150	23	174	98	18-20	
155938	200	23	224	110	25-30	

ΣΥΝΔΕΣΜΟΙ RAPID

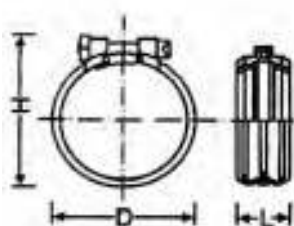

Κωδικός	DN	H (mm)	D (mm)	L (mm)	€ / Τεμ.
157589	50	80	70	40	
155794	70	100	90	40	
157598	100	135	125	46	
157602	125	162	147	55	
157606	150	187	172	55	
157610	200	240	223	55	

ΣΥΝΔΕΣΜΟΣ (ΚΟΝΦΙΧ) ΠΛΑΣΤΙΚΟΥ ΜΕ ΧΥΤΟΣΙΔΗΡΟ

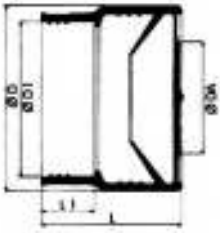

Κωδικός	DN	D1 (mm)	D (mm)	Φ Dα (mm)	L1 (mm)	L (mm)	€/ Τεμ.
155759	50	57	72	40 - 56	20	58,0	
155790	70	77	92	56 - 75	22	66,5	
155833	100	108	126	102 - 110	27,5	89,5	
155883	125	132	151	125	35,5	108,5	

ΧΥΤΟΣΙΔΗΡΟΣ ΣΥΝΔΕΣΜΟΣ

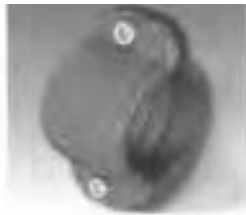
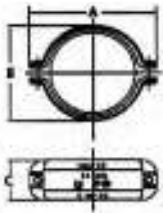

Κωδικός	DN	A (mm)	B (mm)	C (mm)	Kg / Τεμ.	€/ Τεμ.
156398	50	113	79	58	0,60	
156493	70	129	103	58	0,60	
156634	100	170	137	58	0,80	
156777	125	188	183	58	0,90	
156888	150	217	243	80	1,70	
156998	200	278	308	82	3,50	